

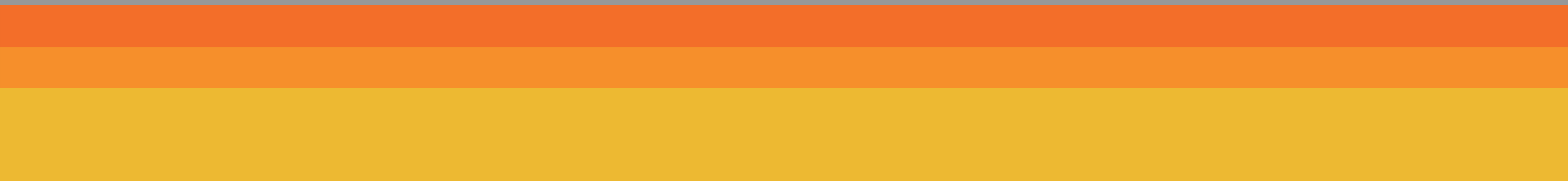

Hightech Industrial Equipment Ltd

Hightech

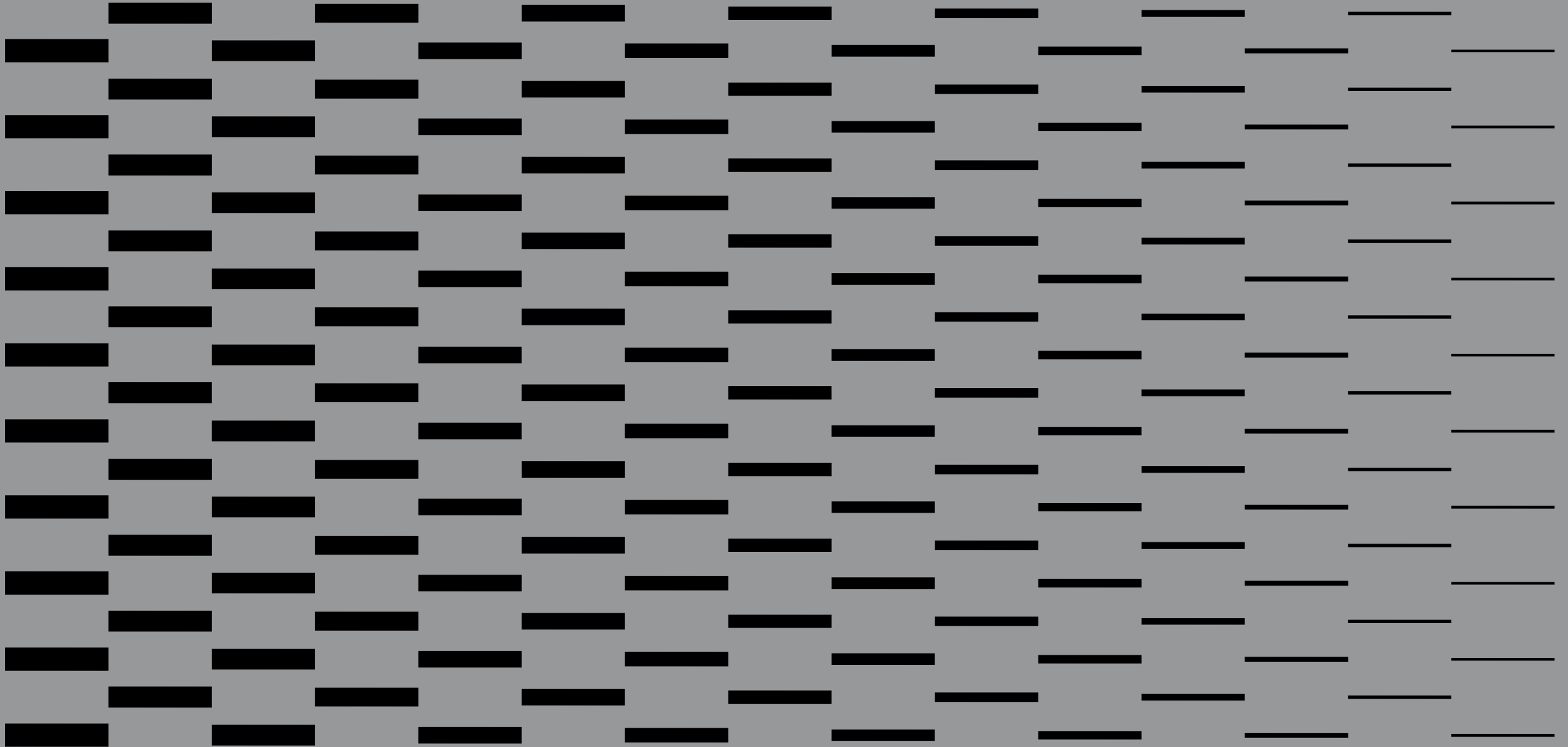



The future is already a reality here

Advanced industrial building

A modern structure spanning over 12,000 square meters

Strategic location



Our purpose



Transforming the operations of leading industries worldwide by providing high-performance machinery solutions.

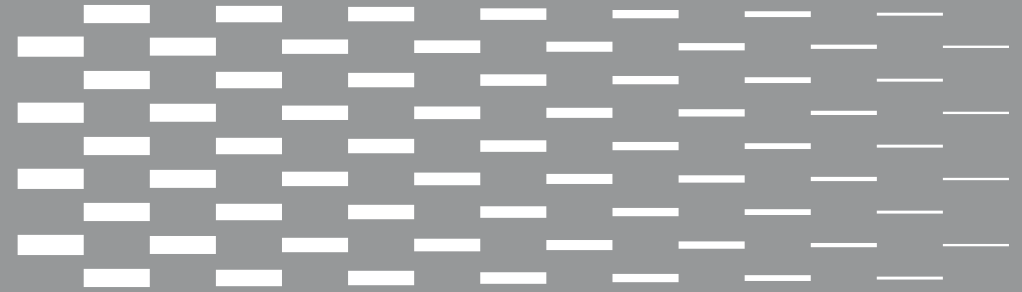

History

Founded in 1988, the company started in the field of consulting and projects to food processing facilities. The HT machine was developed, known as Mechanically Separated Meat (MDM) machine, becoming the leader in the Brazilian market with over 90% share and exporting to 27 countries.

With state-of-the-art technical capacity and cutting-edge technology, Hightech has become a manufacturer of equipment for processing animal proteins, pet food, and collagens, swelling a wide range of equipment in its portfolio.

1988

Today

90% OF THE BRAZILIAN
MARKET SHARE

in the MDM segment.

Assisting over

+ THAN 660 CUSTOMERS

Operating

IN 27 COUNTRIES

Power of transformation in the world

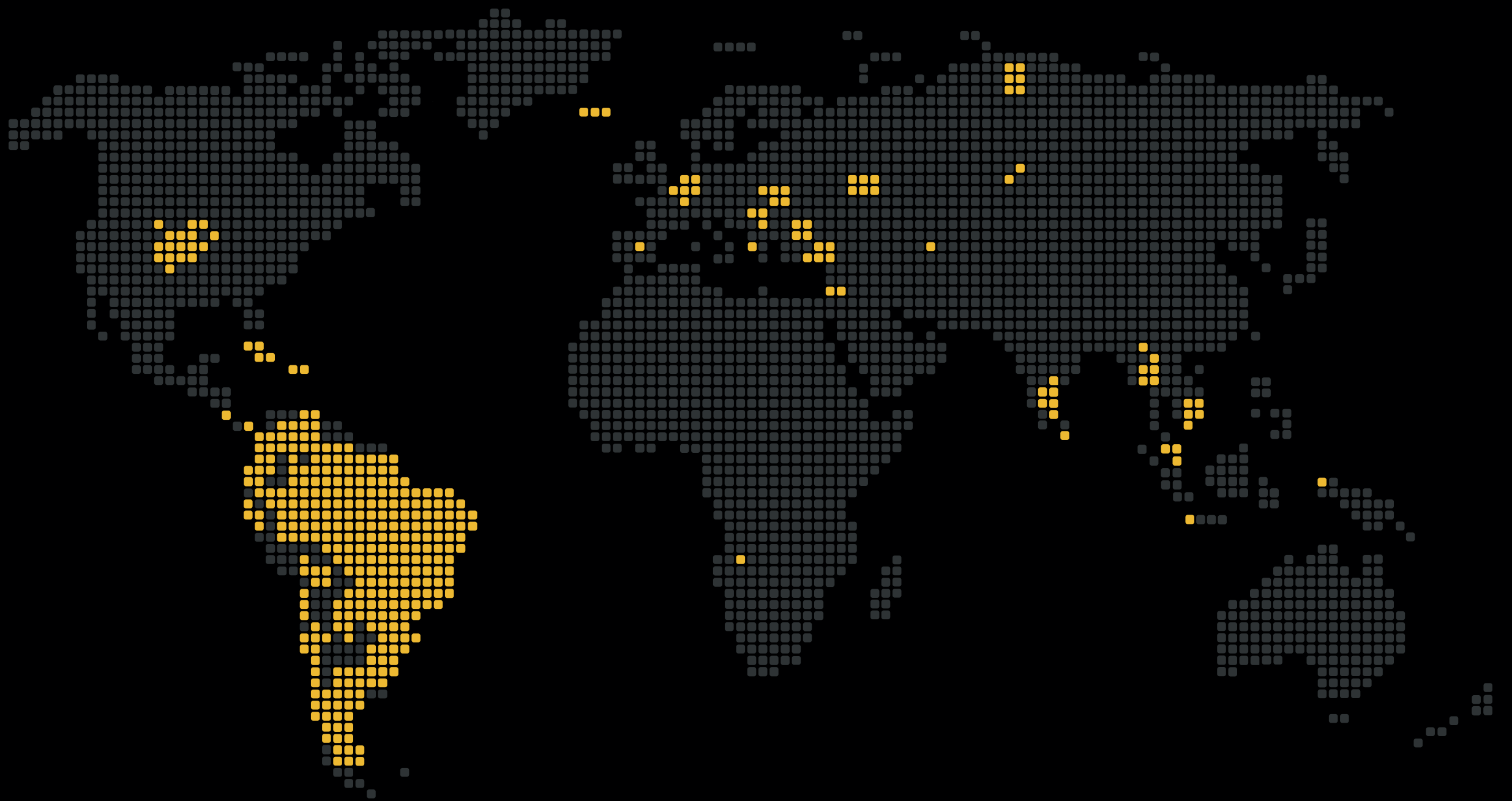

Global horizons

Delivering answers and results to the world.



Creative Stages →

Space to create and innovate, moving challenges into opportunities



Featuring modern and functional spaces dedicated to Engineering, Sales, and Administrative functions, as well as communal areas such as meeting rooms, coffee and gourmet spaces, and relaxation areas, we strive to promote interaction among our employees and customers, promoting accurate information exchange.



Revolutionary Vision

In our Engineering, whether it be Mechanical, Electrical, or Automation, these three segments operate interconnectedly, seeking personalized, creative, and innovative solutions, providing transformative power to meet each customer's needs.

Ready to Assist

Our cutting-edge Sales and Technical departments with a qualified team. We offer sales of machinery, parts, and connected technical support services, aligned to constantly seek solutions for our customers.



High investment in infrastructure and technology

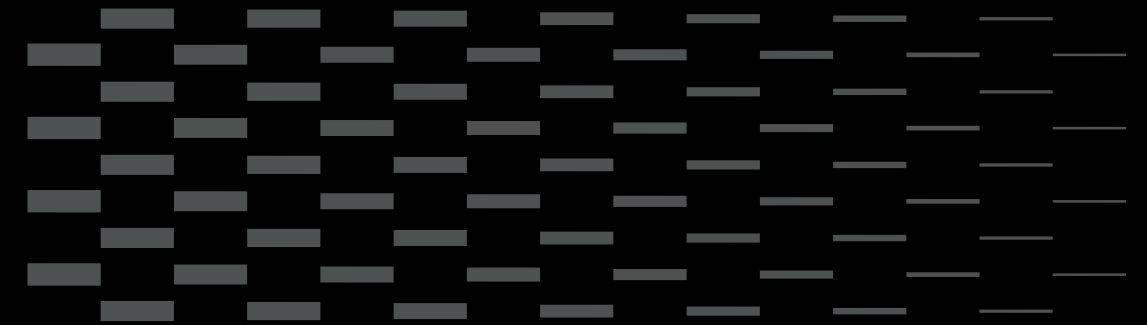

Our manufacturing facility consists of three large buildings. Due to the significant investment in infrastructure and technology, it has the capacity for expansions and layout adjustments. It is a modern industry that enhances efficiency in capacity, ensuring quality and guaranteeing the results of our products and services, leading to significant outcomes.

Building 01

Precision and commitment to delivering the best.

With embedded high technology and rigorous processes, we ensure that our machines are built with quality, robustness, and an extremely high standard of excellence. This area also handles the manufacturing of new parts, as well as providing the necessary technical support for our already installed equipment.

Advanced Technology



- Machining and Parts Repair.

Building 02

Logistics, Efficiency,
and Assembly Quality.

Hightech's industry was designed to meet high standards in its mechanical and electrical assembly processes, striving for excellence and technology. An assembly sector with efficient logistics, to bring the quality and robustness of Hightech products to industries worldwide.

Hightech Quality



- Mechanical and Electrical Assembly, and Warehouse.

Building 03

Durability, performance, and efficiency are key aspects of everything we do.

Our goal is to maintain a high standard and attention to detail in everything we do, from designing a new machine to implementing an innovation, thus increasing our customers' productivity capacity. Every aspect is precisely considered, from welding quality to finishing, to ensure that Hightech equipment delivers performance, robustness, and efficiency in processing food across various industry segments.

Concern & Power



- Welding Sector and Finishing Surface.



Our newest customer service tool.

Hightech constantly strives to better assist its customers, whether through new equipment or assistance in parts and services. The Hightech Tour has two goals: to bring you to Hightech and demonstrate our industry, and to conduct training sessions. On the other hand, our team can visit your site, bringing equipment and conducting field tests.

The Hightech Tour is a personalized tool that allows our customers close contact to showcase the quality and innovation of our products and services.



| Testing Lab

Hightech has invested in the development of a modern and efficient testing lab. The customers are able to bring their products for processing and confirm the desired results. Investing in Hightech machine ensures security and trustworthy results.



| Customer Space

Everything is developed to provide comfort and safety. During the customer's visit to our industry, for a test or even a meeting, we have a specially organized room to make the customer feel at home, with all the comfort and privacy, so they can rest and carry out their activities while waiting.

A low-angle photograph of a modern building. The building features a large glass facade on the left and a bright yellow section on the right. A dark, overhanging roof structure is visible at the top. The sky is clear and blue. A small tree is visible in the bottom left corner. The text "Lean on a leading industry_" is overlaid in white, centered on the image.

Lean on a
leading industry_

High-performance machines that feed the world

Find out our solutions



Double helical shaft
to bone separation



Easy cleaning
separation system

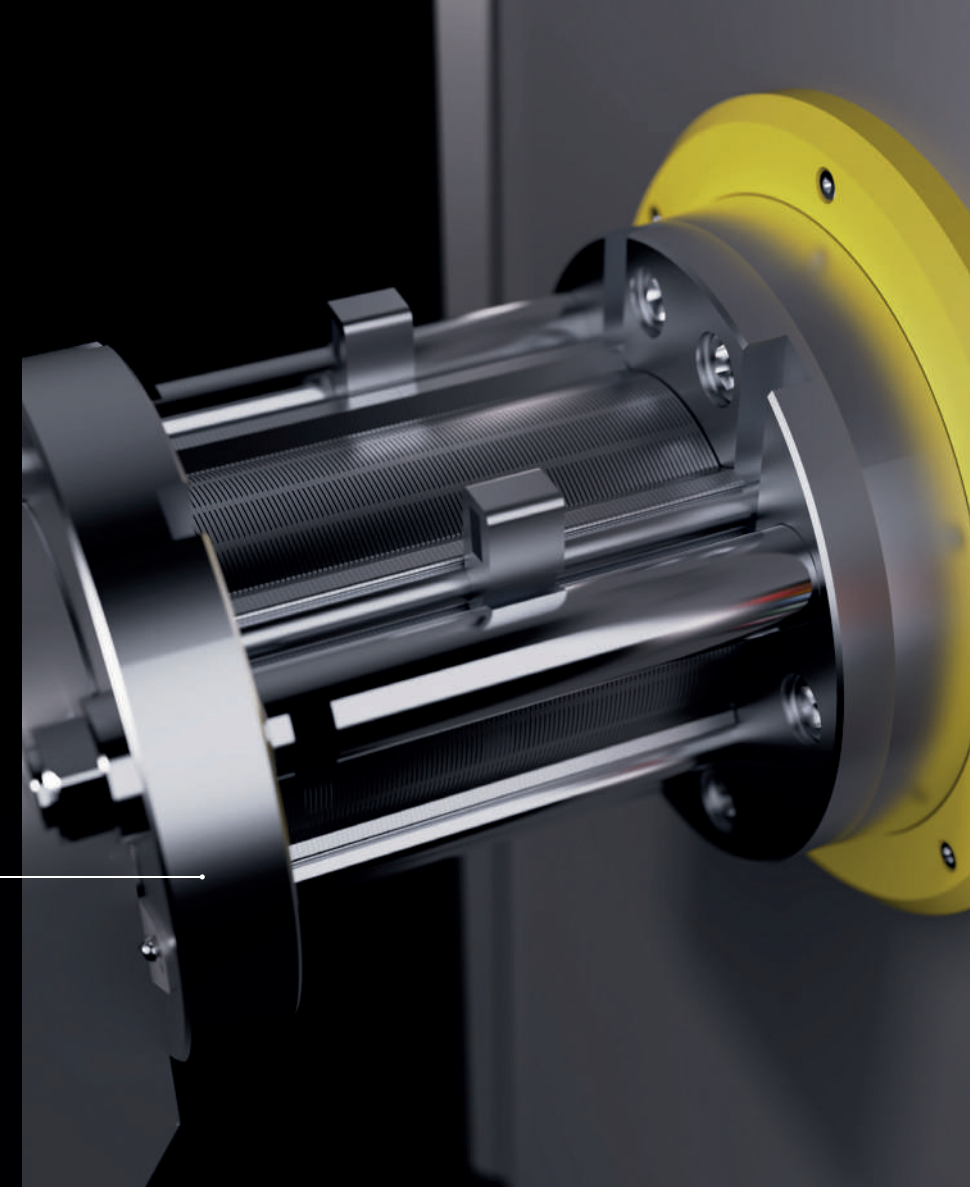

Separator HT

Capacity: 150 a 9,000 kg/h

Applications



• Animal and plant proteins

• Fruits

See the complete line in: hightech.ind.br

Level control

Automatic pressure control

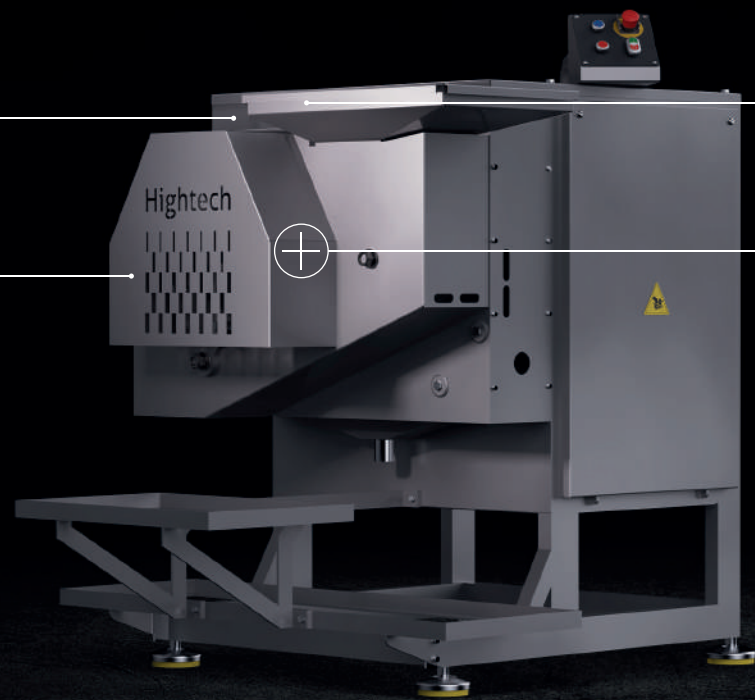

Automatic pusher

Diverse range hole sizes of the separator basket

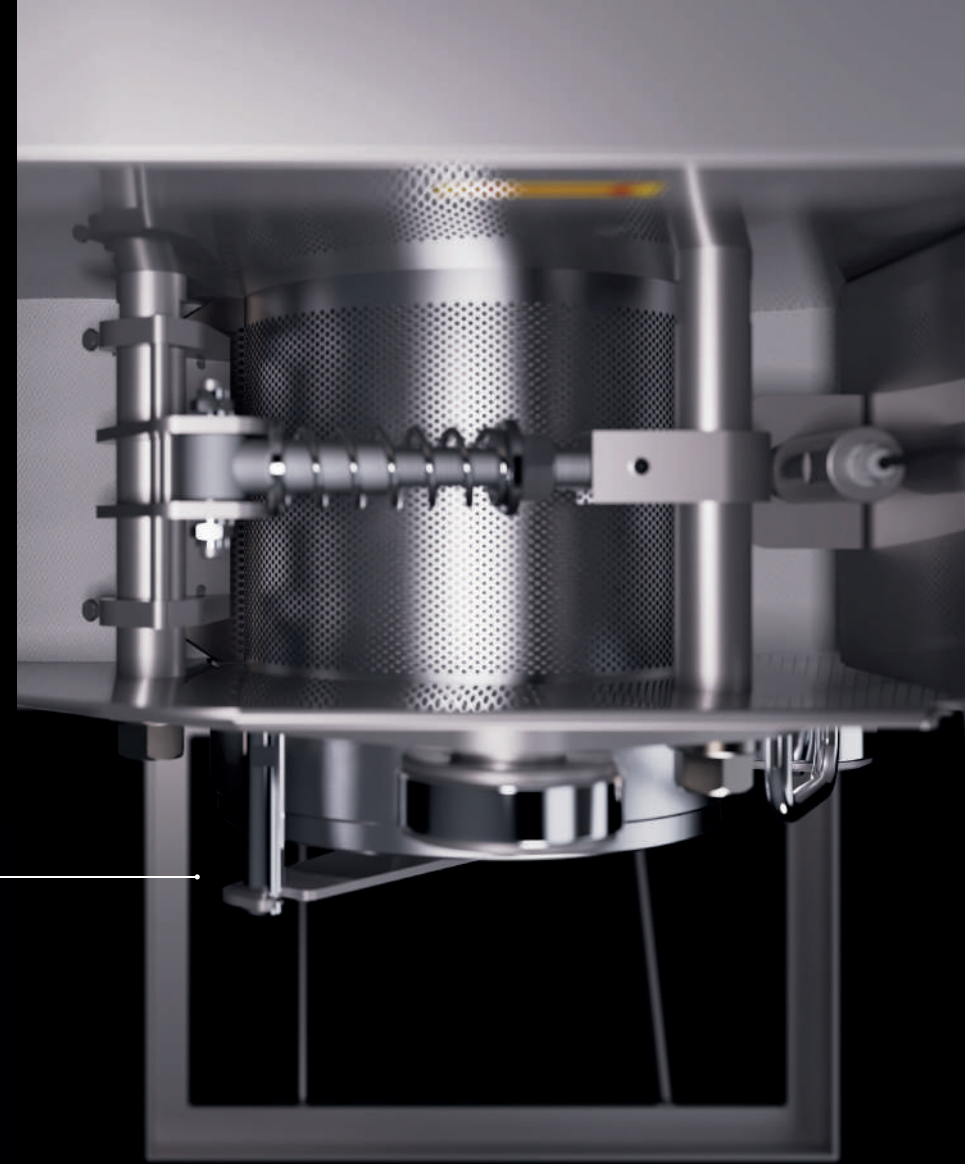

Separator HT BELT

Capacity: Up to 1,200 kg/h

Applications



• Animal and plant proteins

• Fruit pulp

See the complete line in: hightech.ind.br

Cutting set up to 2 discs
with diameters of 200
and 280 mm



Helical shafts to break
and grind the product

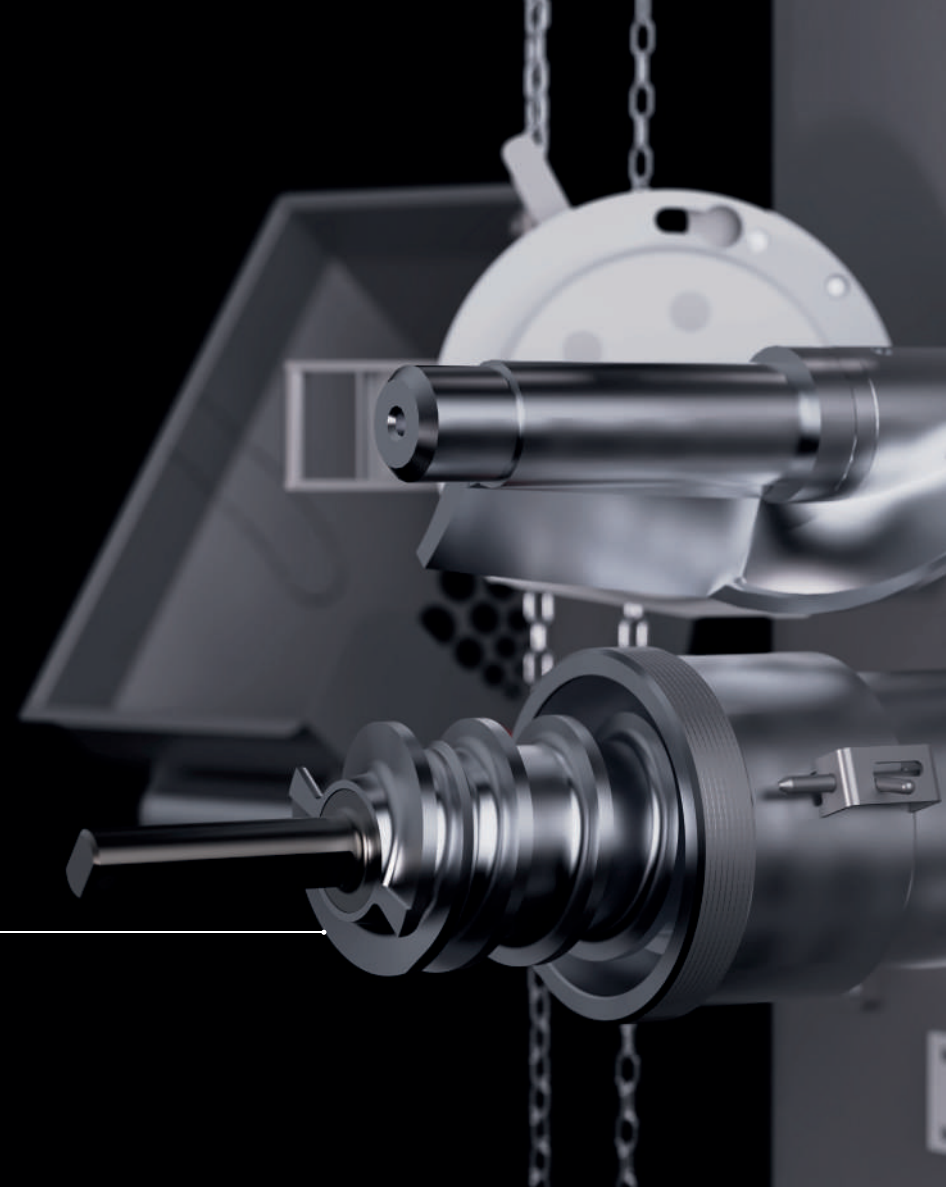

Grinder MG

- Capacity: Up to 20,000 kg/h
- Breaker speed control
- Raw materials with temperatures starting from -18°C

Applications



• Animal and plant proteins • Fruits • Vegetables

• Poultry feathers • Skins

See the complete line in: hightech.ind.br

Cutting set up to 2 discs
with diameters of 130
to 400 mm



Applications



• Animal and plant proteins

• Fruits • Vegetables

Grinder MO

Capacity: Up to 15,000 kg/h
• Raw materials with temperatures starting from -18°C

See the complete line in: hightech.ind.br



Separation system



Feed system with double helical shaft

Agitator

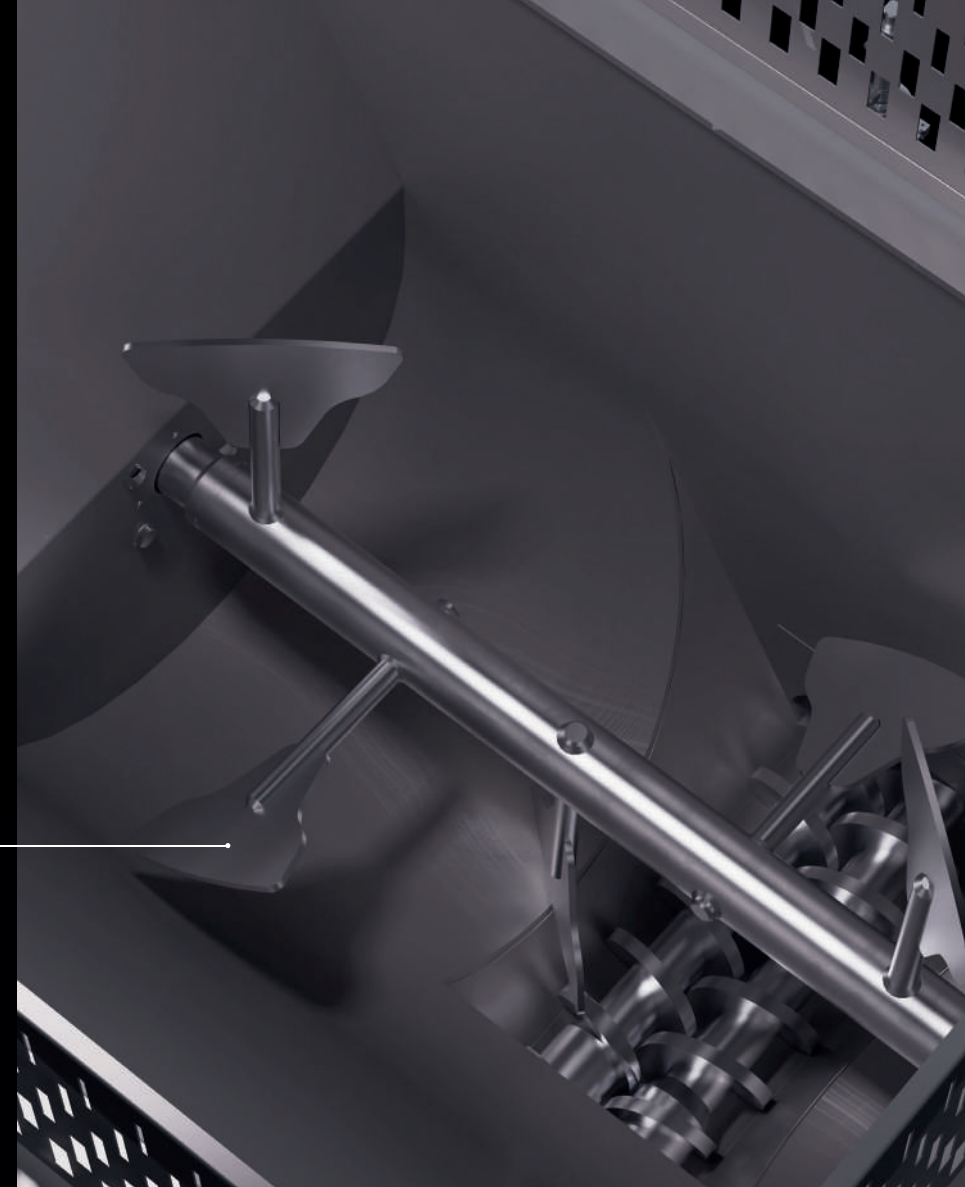

Grinder MS

Capacity: Up to 3,000 kg/h

Applications



• Animal and plant proteins

See the complete line in: hightech.ind.br

Lids

Front or bottom
discharge

Recipe storage

Vacuum
system

Automatic
water dosing

Paddles

Bowl heating

Weighting system

Mixer MT

Capacity: 150 to 5,000 liters

Applications



• Pastas • Sauces • Fruits • Vegetables

• Chocolates • Animal and plant proteins

See the complete line in: hightech.ind.br

Lids

Recipe storage

Weighing system

Automatic
water dosing

Helicoidal paddles

Vacuum
system

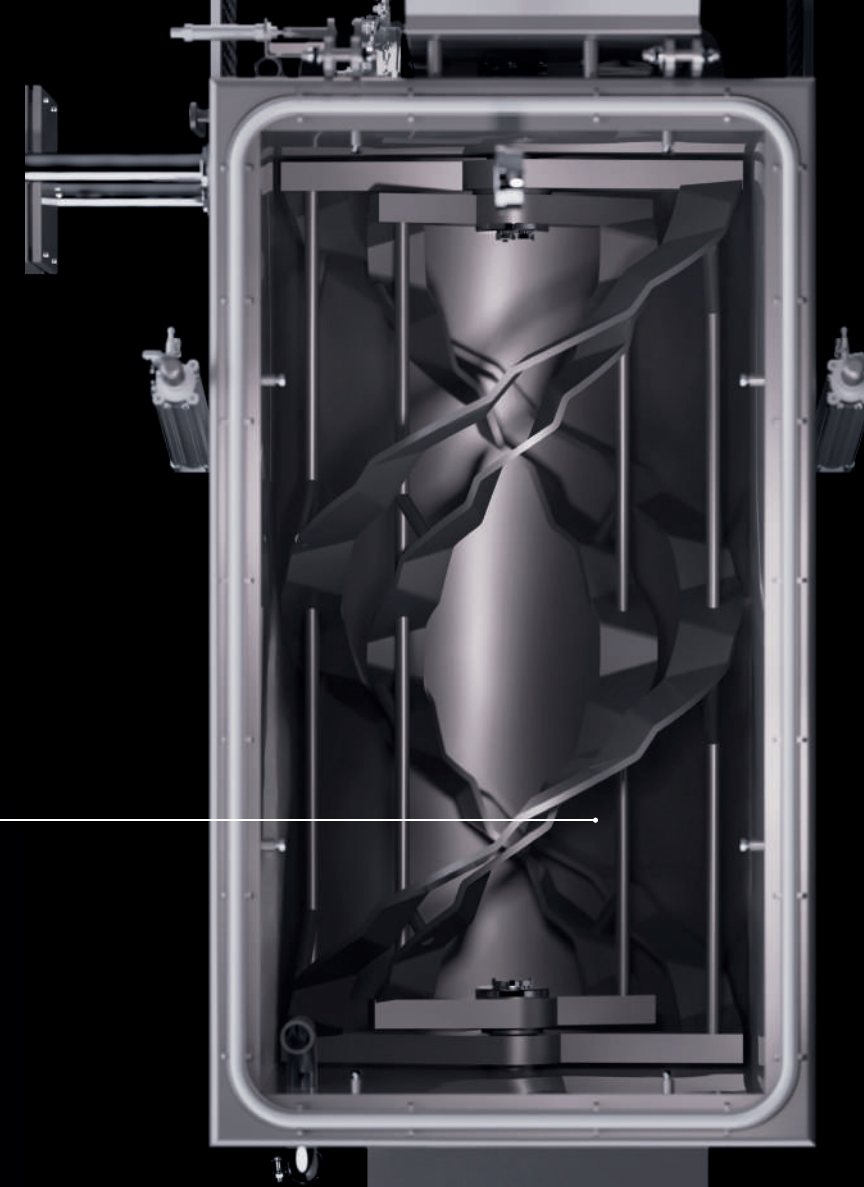

Mixer MTH

Capacity: 150 to 5,000 liters

Applications



• Pastas • Sauces • Emulsions

• Chocolates • Animal and plant proteins

See the complete line in: hightech.ind.br

Pressure monitoring

Coolant fluid circulation jacket

Safety sensor



Polyurethane insulation

Temperature control

Weighing system

Vacuum system

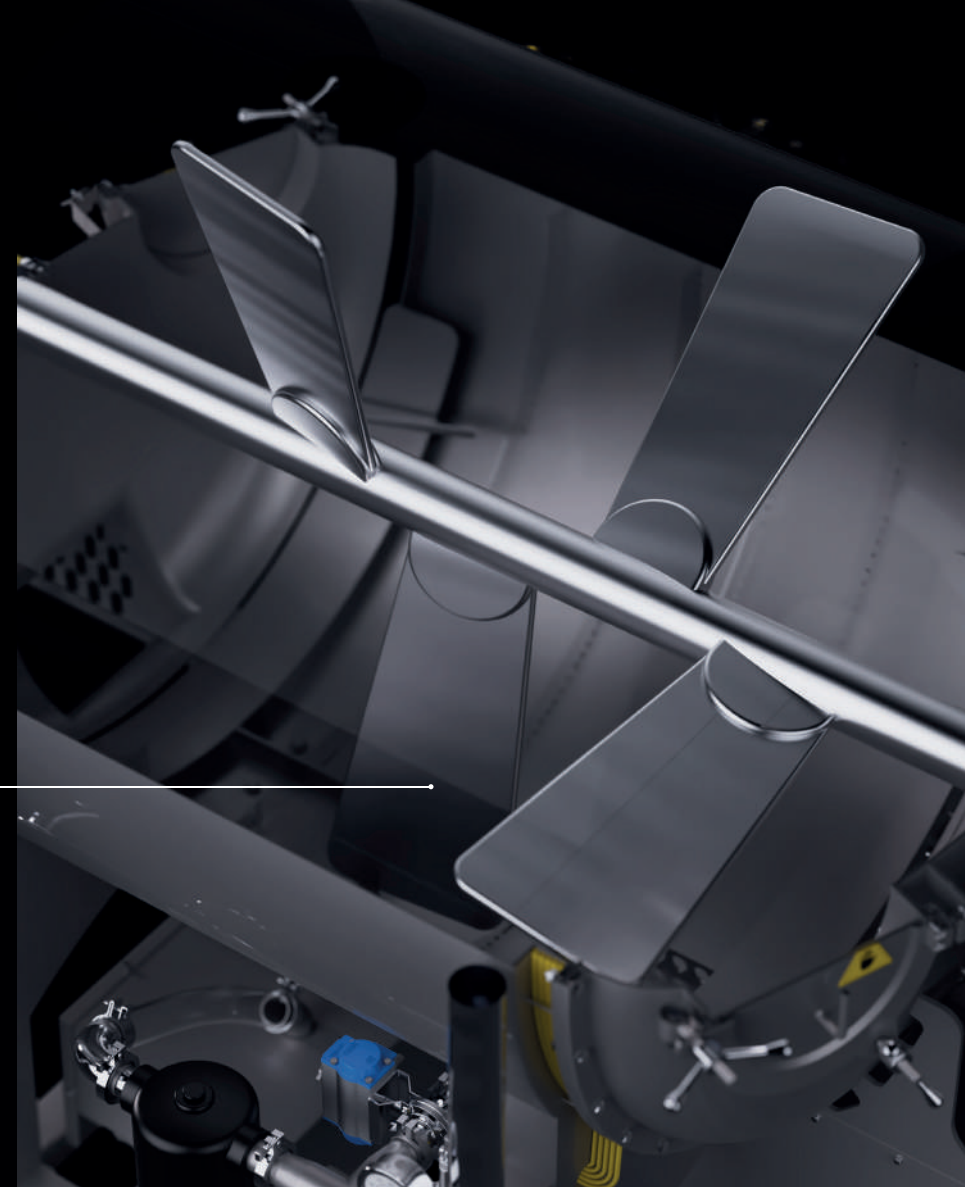

Applications



• Bacon

• Marinade

• Ham

Massager MAS

Capacity: 450 a 10,000 liters

See the complete line in: hitech.ind.br

Level control

Temperature and pressure control

Positive displacement pump

Vacuum system

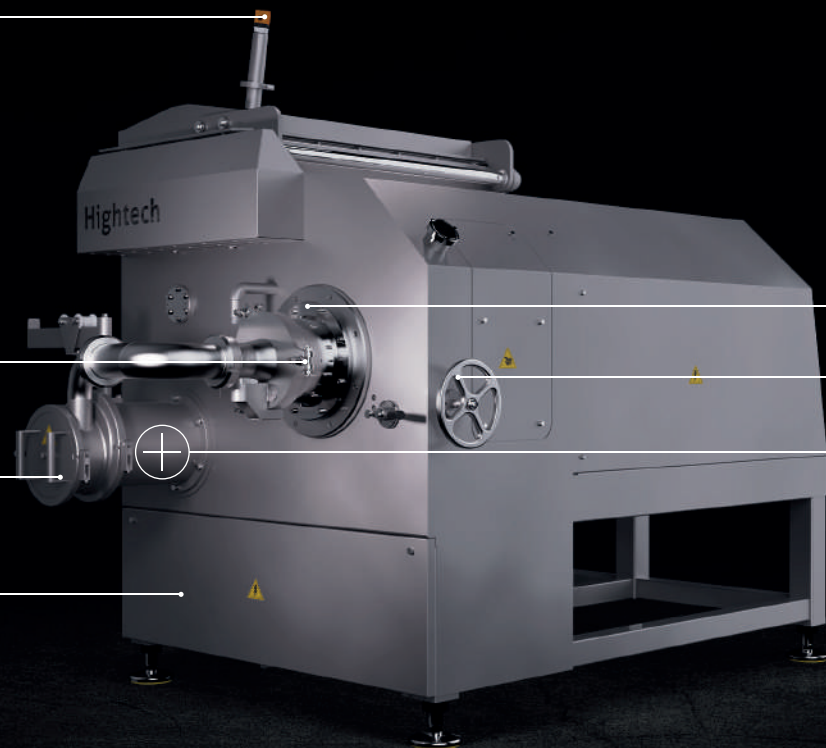

Automatic and semi-automatic control

Manual control

Up to 4 cutting sets

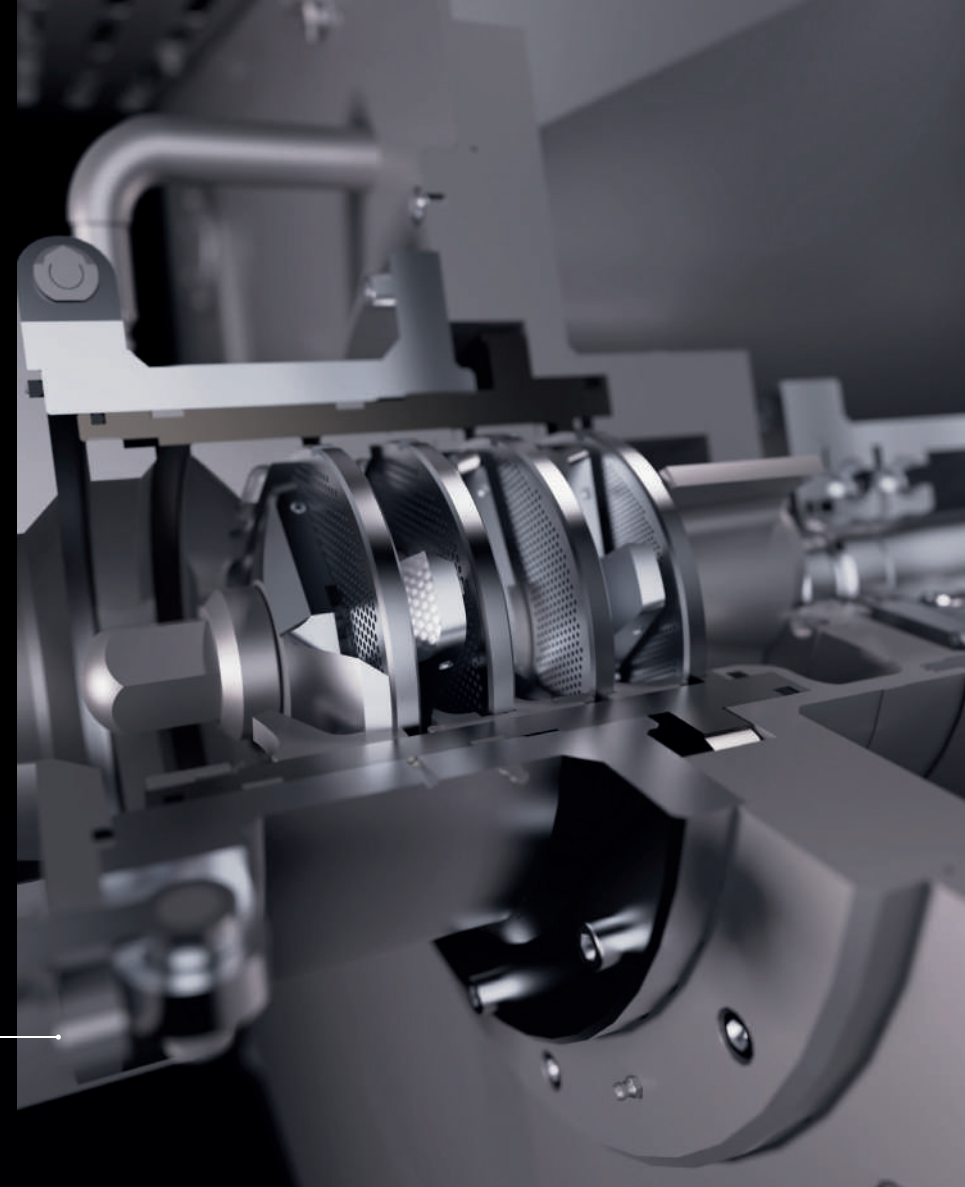

Emulsifier EM

Capacity: Up to 7,000 kg/h
• Cutting set with diameters of 150, 175 and 225 mm

Applications



• Mortadella • Sausage

• Chocolates • Jam • Emulsions

See the complete line in: hightech.ind.br

Ergonomic
cleaning support

Product heating
or cooling

Different types
of coolant fluids



Scrapers in
different materials

Temperature
control

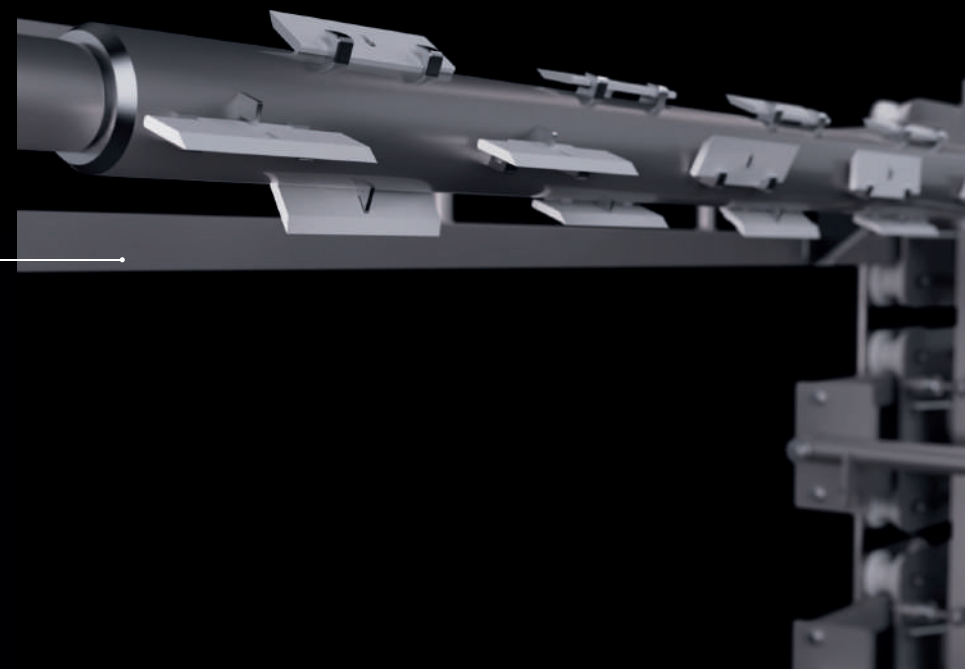

Scraped Surface Heat Exchanger TSR

Capacity: Adjusted to
customer requirements

Applications



• Pastas • Sauces

• Flavourings • Emulsions

See the complete line in: hightech.ind.br



Knives



Breaker QD, QR, and QS

Capacity: Up to 10,000 kg/h

Applications



• Frozen blocks (animal and plant proteins)

• Carcass • Bones

See the complete line in: hightech.ind.br

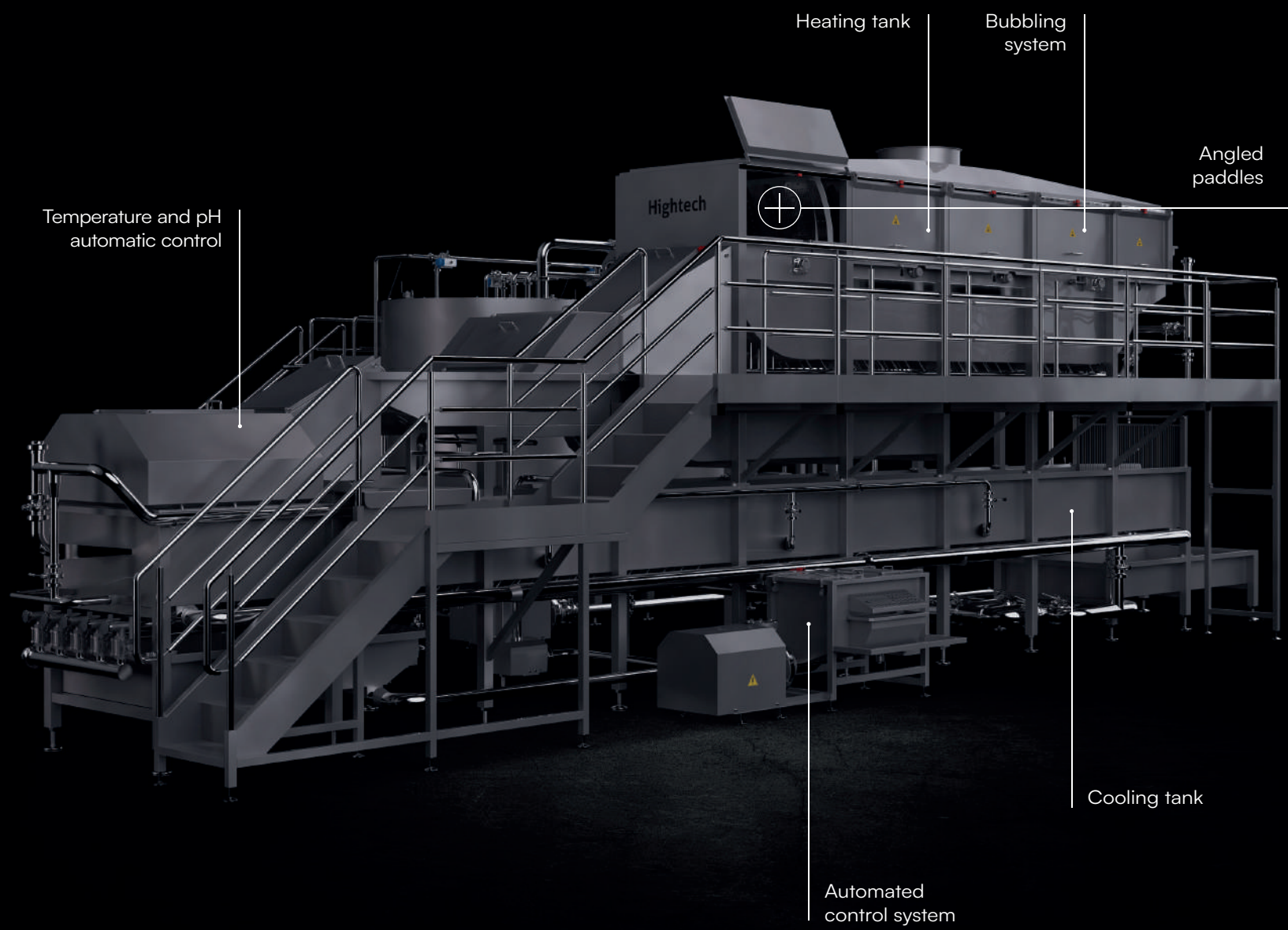

Colouring System ST

Capacity: Up to 7,000 kg/h
 • Sausage breakage and Annatto consumption reduction

Applications



• Sausage

See the complete line in: hightech.ind.br

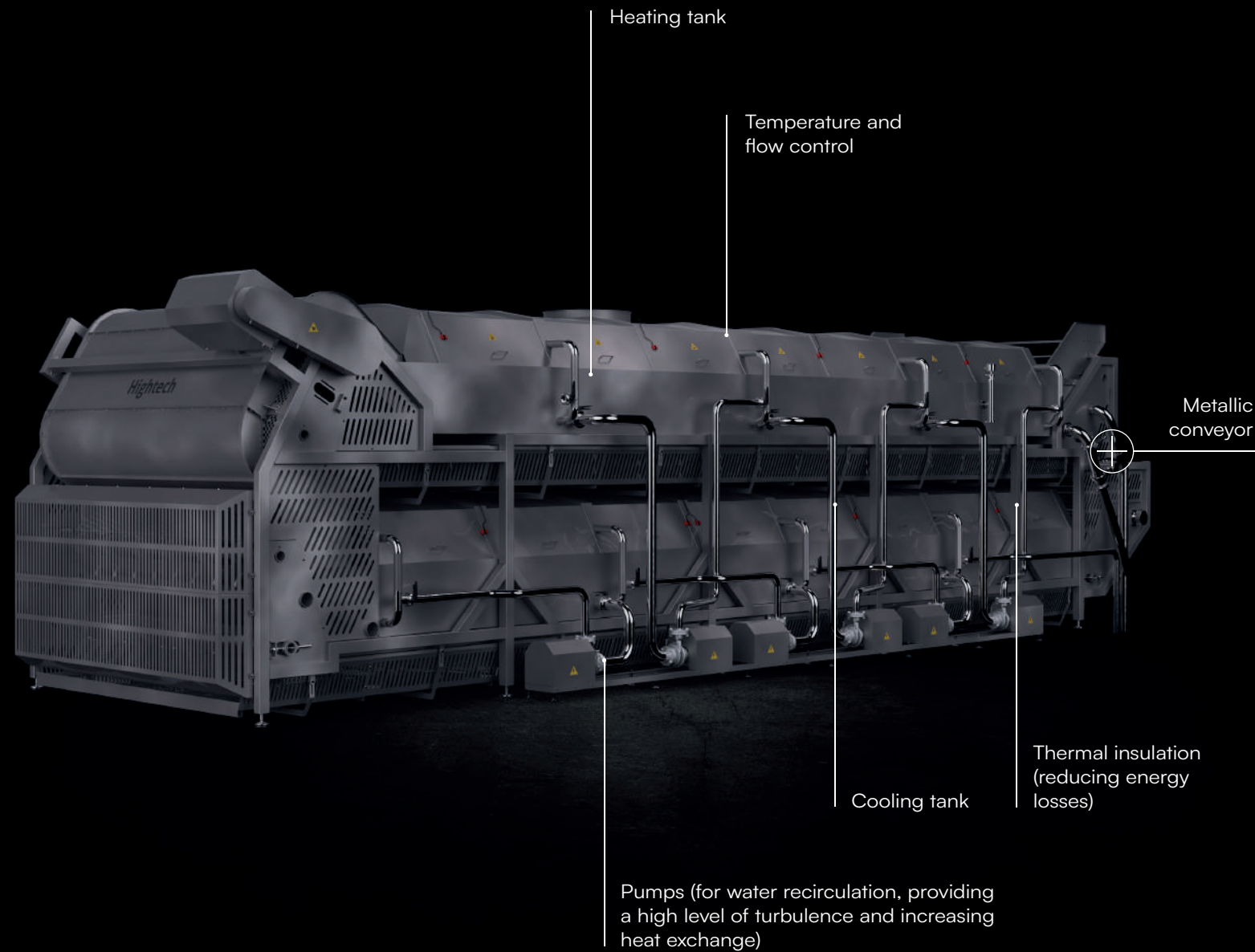
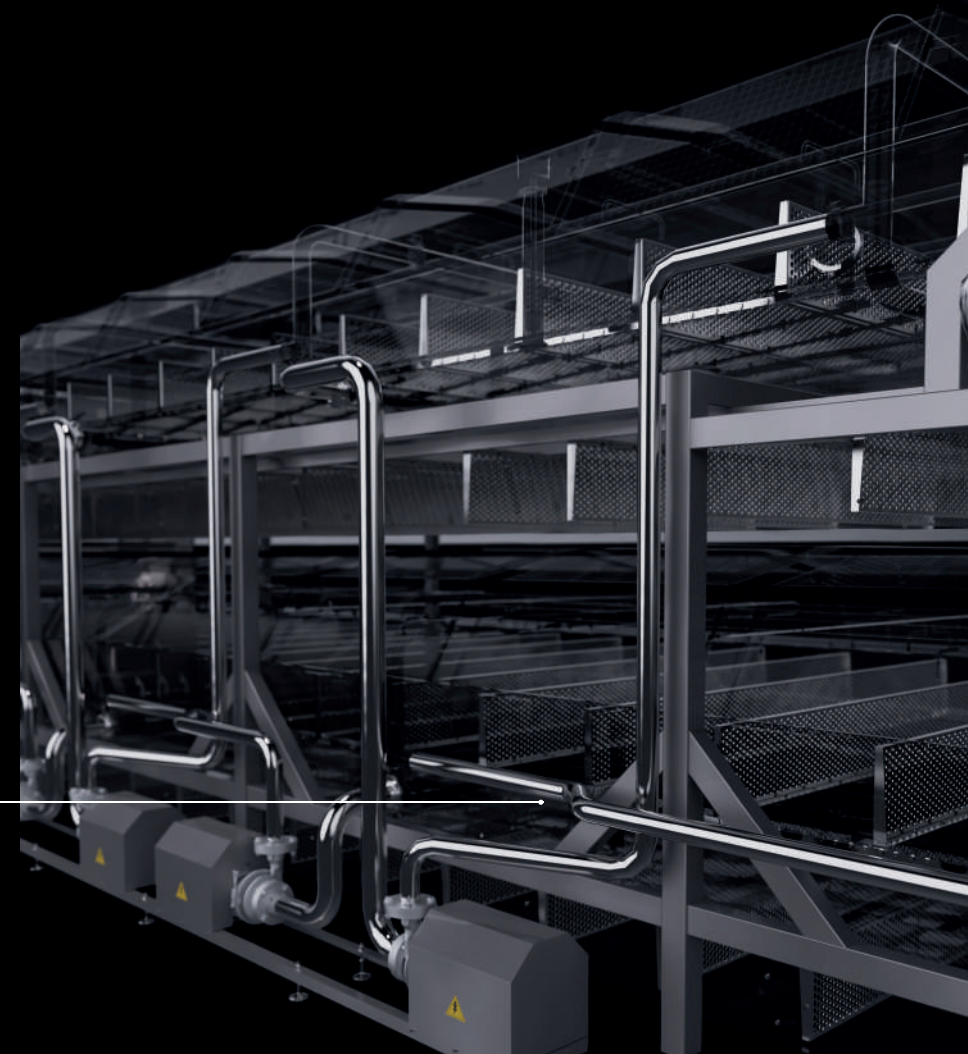

Pasteurizing System PC

Capacity: Up to 7,000 kg/h

Applications



• Animal and plant proteins

• Packaged products

See the complete line in: hightech.ind.br

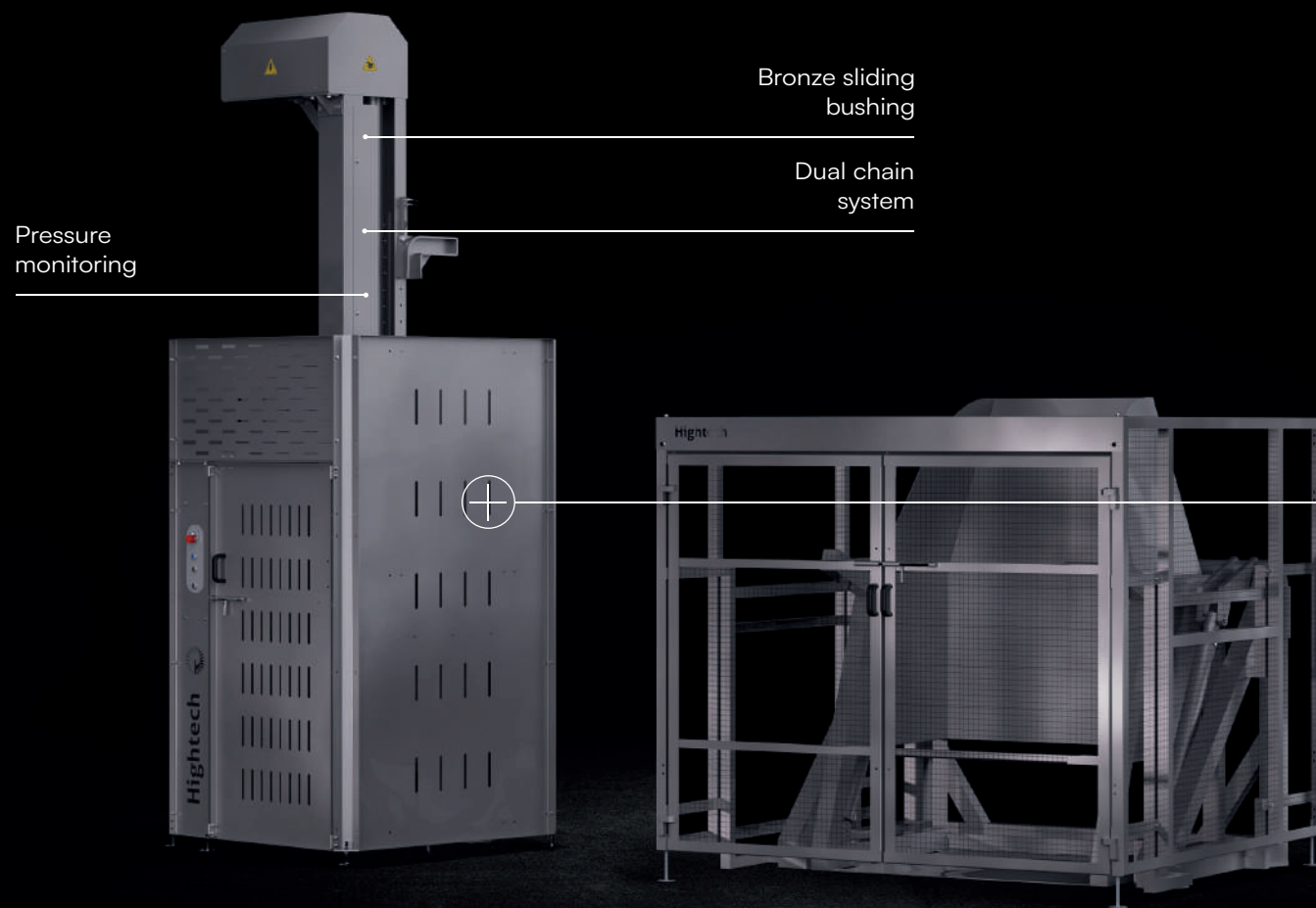

Elevator EC and Lifting TH

Capacity: Adjusted to
customer requirements

Features



- Hydraulic
- Chain-driven

- Single or double column
- Pantograph

See the complete line in: hightech.ind.br

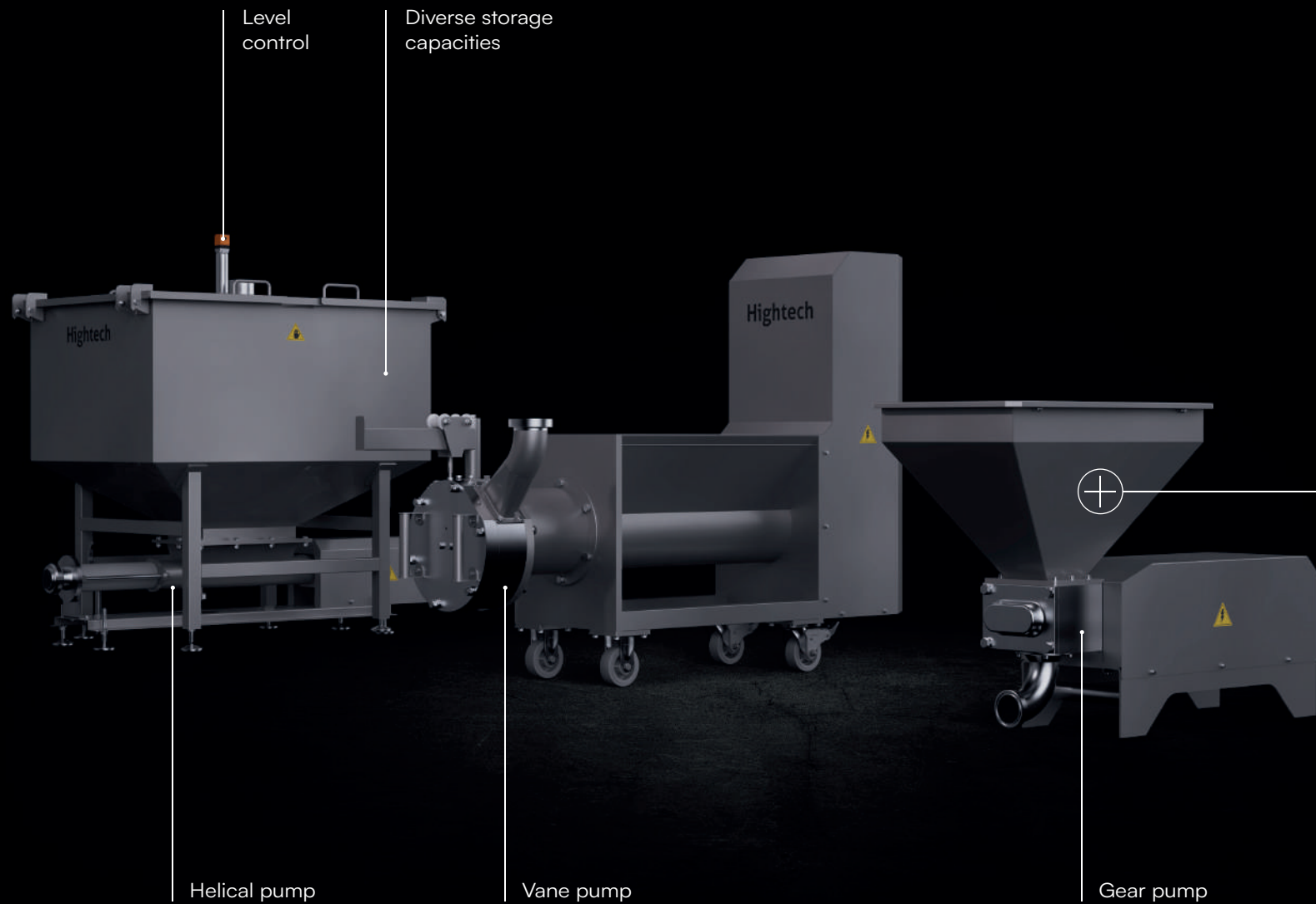

Pump BP, BE, and SB

Capacity: Adjusted to customer requirements

Applications



• Mechanically Separated Meat (MDM)

• Viscous products

• Emulsions

See the complete line in: hightech.ind.br

Inclination angles
up to 90°

Diverse helical
diameters

Diverse raw materials

Diverse types
of conveying
elements



Belt Conveyor ES and Screw Conveyor TRH

Capacity: Adjusted to
customer requirements

Features



• Modular • Flat • Polyurethane

• Helical • Polypropylene

See the complete line in: hightech.ind.br

Stainless or
carbon steel

Diverse degree
size reduction

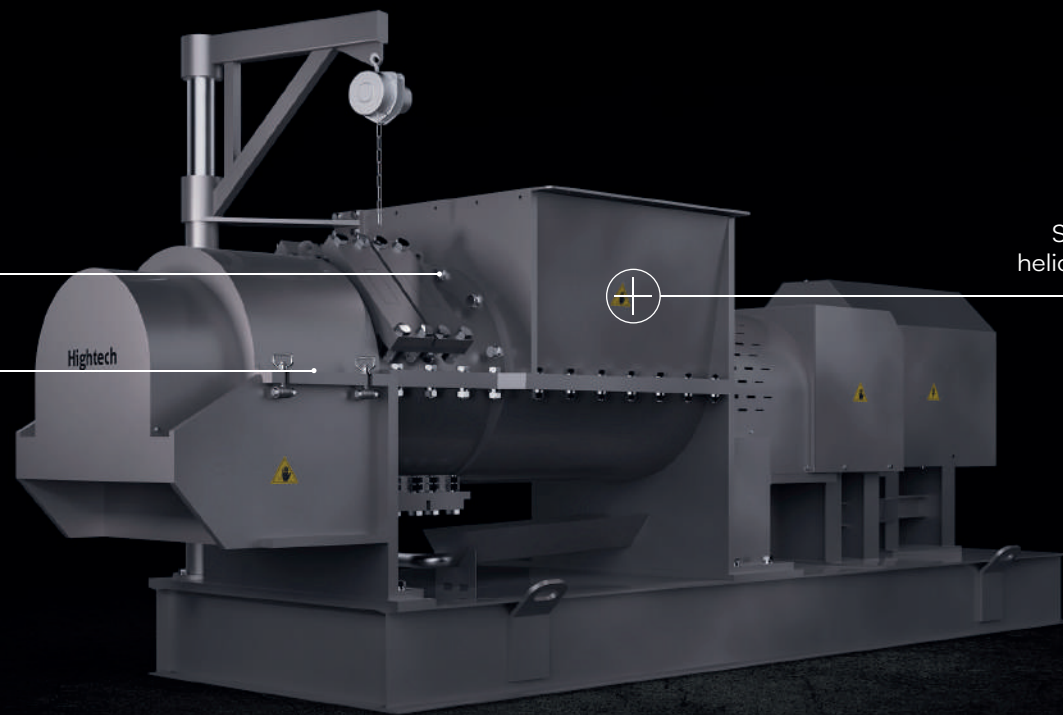

Surface treatment of
helical shaft and blades

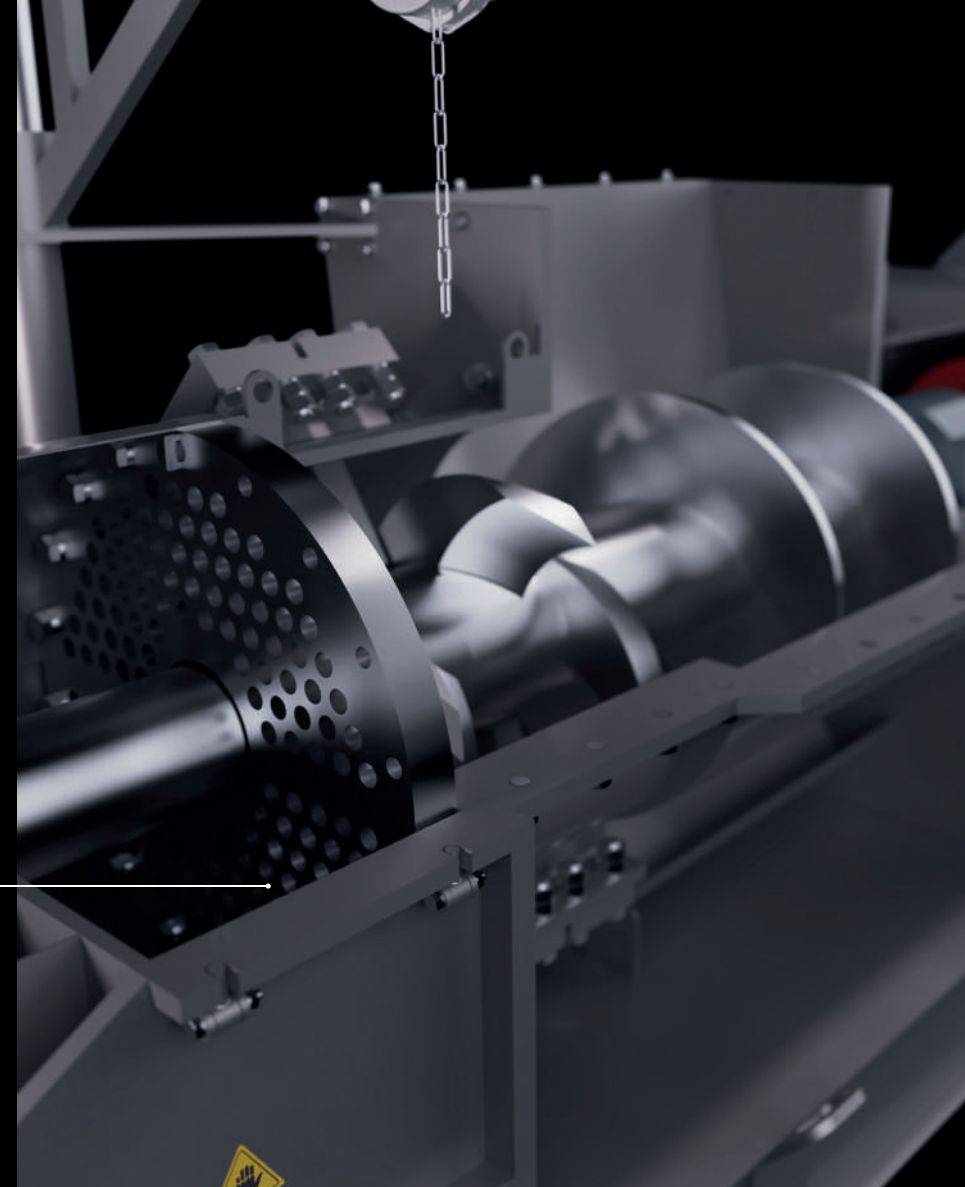

Applications



• Skins

Pre-Breaker QP

Capacity: Up to 10,000 kg/h

See the complete line in: hightech.ind.br



Transform your industry
with the power that only
Hightech has_



Technology and machining center

The best ind technology and technical knowledge

Economic and efficient repair

Increase the service life of your equipment



CUSTOMIZED SOLUTIONS

We provide tailor-made components for Grinders, Emulsifiers, and MDM Machines, ensuring fast and efficient solutions to meet the specific demands of a wide range of needs.

COMPLETE REPAIR OF PARTS AND FUNCTIONALITIES

With our technological and accurate service, we secure an extended service life for your equipment. Our innovative approach and advanced manufacturing techniques ensure the efficient and economical repair of your parts, ensuring the continuous operation of your production in a reliable and high-quality mode.

Ready to meet your needs

SUPPORT AND MAINTENANCE SERVICES

Our team is prepared and committed to delivering specialized technical assistance, ensuring the continuous and optimal performance of your equipment. Our goal is to enhance operational efficiency, contributing to maximizing production and reducing maintenance costs.

Emulsifier

Cutting discs and knives.

Heat Exchanger

Jackets, scraper blades, bushings, and seals.

Separator

Helical shafts, separator blades, separator baskets, bearing units, and output regulators.

Grinder

Cutting discs, pre-cutting discs, knives and bushings.





hightech@hightech.ind.br | + 55 (49) 3361.5555

89815-284 | SC-480 Highway, km 147 - | Chapecó-SC | Brazil